

READ, UNDERSTAND AND FOLLOW ALL INSTRUCTIONS IN THIS MANUAL - DO NOT DISCARD.
Failure to follow these instructions could result in property damage, serious injury or death.

QUICK START INSTRUCTIONS

WAPC250

STEP 1 - VERIFY PACKAGE CONTENTS

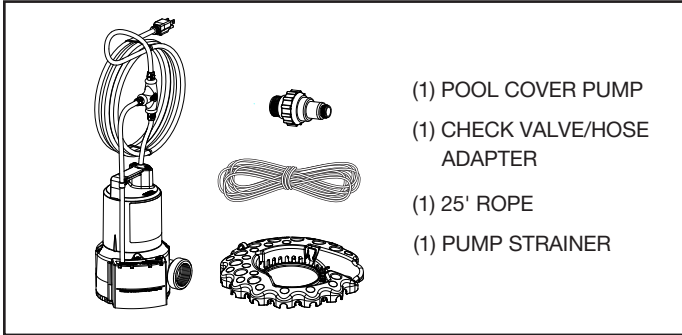

STEP 5 - SECURE ROPE TO STRAINER

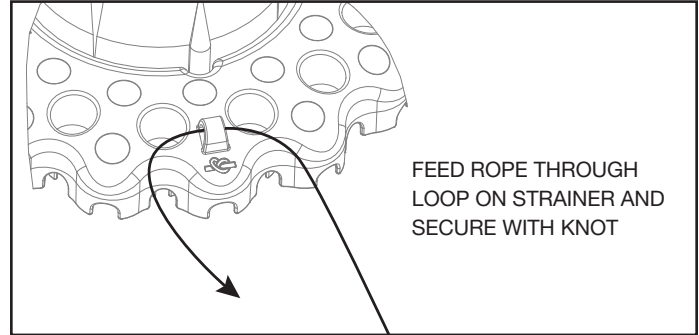

STEP 2 - INSTALL CHECK VALVE

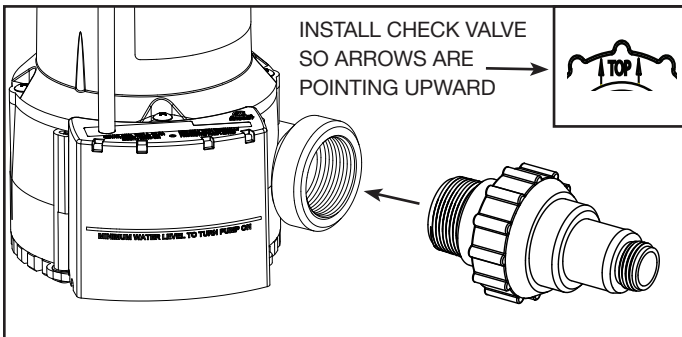

STEP 6 - POSITION ON POOL COVER

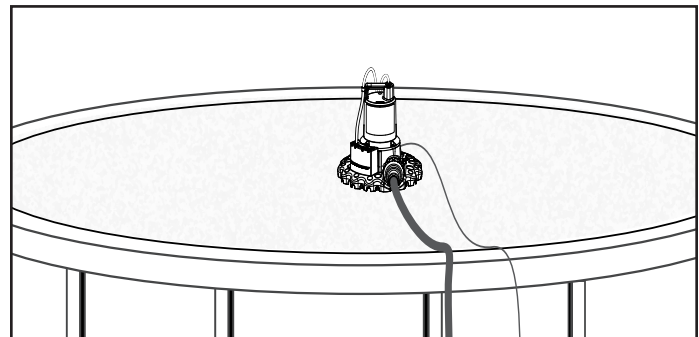

STEP 3 - ATTACH STRAINER

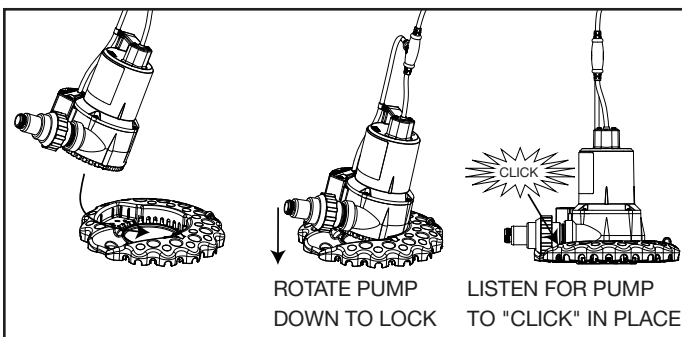

STEP 7 - PLUG INTO GFCI OUTLET

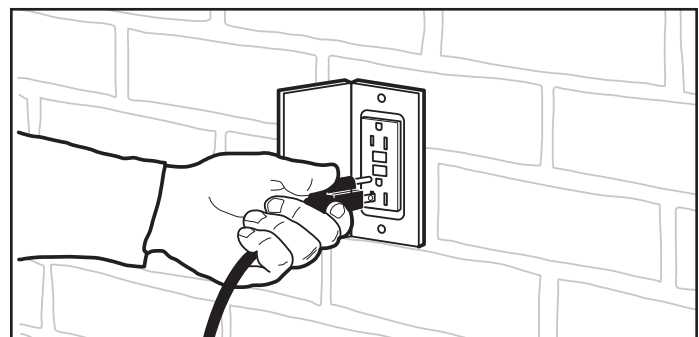

STEP 4 - CONNECT GARDEN HOSE

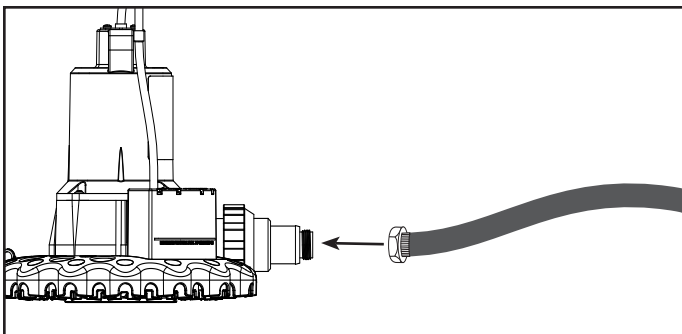

FOR FURTHER PLACEMENT TECHNIQUES AND DETAILED INSTALLATION FOR INGROUND AND ABOVE GROUND POOL APPLICATIONS, REFER TO PAGE 3 - FIGURES (A-E).

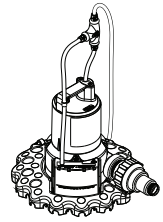

READ, UNDERSTAND AND FOLLOW ALL INSTRUCTIONS IN THIS MANUAL - DO NOT DISCARD.
Failure to follow these instructions could result in property damage, serious injury or death.

WAPC250

DESCRIPTION

This portable, Auto On-Off Pool Cover pump is designed for automatic removal of water, from a pool or spa cover. The units are equipped with a 25 ft. 3-prong grounding type power cord. The provided discharge check valve prevents short cycling and it's 3/4 in adapter can be used for convenient attachment to a standard garden hose.

UNPACKING

Inspect this unit before it is used. Occasionally, products are damaged during shipment. If the pump or components are damaged, contact customer service at 1-800-237-0987.

SAFETY GUIDELINES

To help recognize this information, observe the following signal words/hazard classifications.

 **This is the safety alert symbol. It is used to alert you to potential bodily injury hazards. Obey all safety messages that follow this symbol to avoid possible harm.**

DANGER Danger indicates an imminently hazardous situation which, if NOT avoided, WILL result in death or serious injury.

WARNING Warning indicates a potentially hazardous situation which, if NOT avoided, COULD result in death or serious injury.

CAUTION Caution indicates a potentially hazardous situation which, if NOT avoided, MAY result in minor or moderate injury.

NOTICE Notice indicates important information, that if NOT followed, MAY cause damage to equipment.

NOTE: Note indicates information that requires special attention.

GENERAL SAFETY INFORMATION

GENERAL SAFETY

- Read the manual(s) included with this product carefully. Be thoroughly familiar with the controls and the proper use of the equipment. Follow all instructions. 
- Only persons well acquainted with these rules of safe operation should be allowed to use the unit. *Keep away from children!*

DANGER This pump is NOT rated for use with flammable/combustible liquids vapors or dusts. Do NOT use to pump flammable/combustible liquids vapors or dusts. Do NOT use in a flammable and/or explosive atmosphere. Pump SHOULD be used to pump clear water ONLY. Failure to follow these instructions WILL result in bodily injury or death. 

DANGER Electric shock hazard! GFCI receptacles will provide protection against line to ground faults only. The ground fault receptacle does NOT limit the magnitude of fault current and will NOT prevent an electrical shock. Replace damaged cord immediately. 



DANGER Do NOT disassemble or alter this product in any way. Failure to follow these instructions WILL result in serious injury or death. 

WARNING Risk of electric shock. This pump has NOT been tested for use in marine areas. NEVER place pump in pools while people are in the water. Do NOT handle pump with wet hands or when standing in water or on a damp surface. Pump is designed to be used in closed and covered pools only. Water accumulated on pool cover can cause injury or death. Proper installation of pool cover pump and periodic maintenance is recommended. Failure to follow COULD result in death or serious injury.

1. Wear safety glasses at all times when working with pumps. 
2. The unit MUST be plugged into a properly grounded GFCI outlet. Consult with a qualified electrician for proper installation of a GFCI OUTLET.
3. DO NOT MOVE, POSITION, RETRIEVE, OR CARRY PUMP USING THE POWER CORD OR THE DISCHARGE HOSE, damage to the pump or power cord may occur. Use the handle supplied on the pump or attach a string to the strainer to position as instructed.

APPLICATION AND OPERATION

DANGER Do NOT use pump if any part of the housing switch or probe is cracked, broken, or missing.

DANGER Always disconnect electric supply before attempting to install, service, relocate, or perform any maintenance. If the power source is out of sight, lock and tag in open (off) position to prevent unexpected power application. Failure to do so WILL result in fatal electrical shock!  

DANGER Electric shock hazard. Use only Underwriters Laboratories (UL)- listed extension cord with #16 gauge or larger wire that is labeled for outdoor use. Use polarized grounding type plugs only. Polarized plugs have one blade slightly wider than the other and can only be inserted one way into the outlet. If using an extension cord, do NOT allow pump cord/extension cord connection to fall into swimming pool or come in contact with water. Pump/extension cord connection must be kept dry and away from moisture. Do NOT handle plug connector near water. Failure to follow these instructions WILL result in death or serious injury. 

WARNING This unit is NOT designed for use as a sump pump or in sump applications. This unit is NOT designed for use in septic tanks or underground vaults to pump raw sewage or effluents. NEVER use in hazardous or explosive locations. 

REMINDER: Keep your dated proof of purchase for warranty purposes! Attach it to this manual or file it for safekeeping.

For parts, product & service information visit www.waynepumps.com

APPLICATION AND OPERATION (CON'T)

1. This pump has been designed with 1-1/4 in. NPT discharge connection size. Attach pipe or fitting to the discharge or use the supplied garden hose adapter/check valve. Thread the female end of the garden hose to the male end of the garden hose adapter/check valve.
2. Use a hose washer (not included) on the garden hose for correct pump operation.
3. For best pump performance, unwind the hose before starting the pump. This will help remove any kinks or binds in the hose and allow the unit to pump with less restriction.
 - a. DO NOT place the pump on a weak, damaged, or leaking pool cover. Placing the pump on a damaged pool cover could cause the cover to give way, or could allow the pump to remove treated swimming water from the pool in addition to rainwater.
 - b. Install the “snap-on” debris strainer. Begin by lining up the pump base profile with the profile of the strainer base using the switch housing as a guide. Tilt the pump back and guide the rear of the pump (opposite the discharge) into the strainer base. Once the rear of the pump is in place, gently rotate the pump down until the latch engages.
 - c. To remove debris strainer release latch and guide pump out of strainer in the reverse motion of installation.
4. With pump unplugged set the pump on the pool cover, where water will collect. Do NOT set the pump directly on mud, sand surfaces or in leaves. For best results make sure the pump strainer is making full contact with a clean area of the pool cover. This will allow the strainer to properly filter debris and help prevent clogging of the pump. If necessary clear an area of the pool cover before placing the pump. For further placement techniques see (Figures A-E).

DROP-IN PUMP APPLICATION

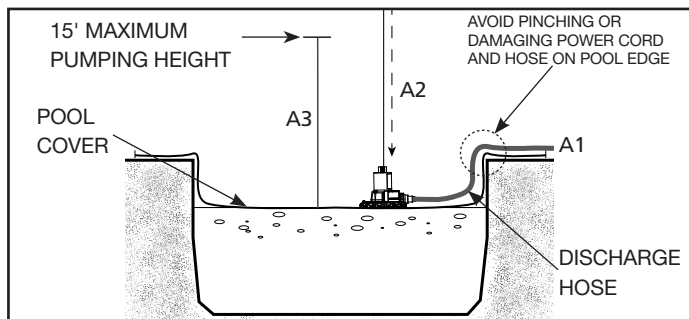

Figure A - In-ground pool installation (cut-away view)

- A1.** Connect discharge hose to pump check valve and place hose end away from pool, where water will be displaced.
 - A2.** Attach provided 25 ft. rope to handle of pump, and lower pump onto pool cover where water will collect.
 - A3.** Do NOT exceed the 15 ft. maximum pumping height for this pump or switch may not function properly. Plug in pump to allow for automatic operation.
- For REMOVAL unplug pump and retrieve using rope.

PULL ACROSS PUMP INSTALLATION

To aid in pump placement on pool cover, secure provided 25 ft. rope to the pull to shore loop (Figure B).

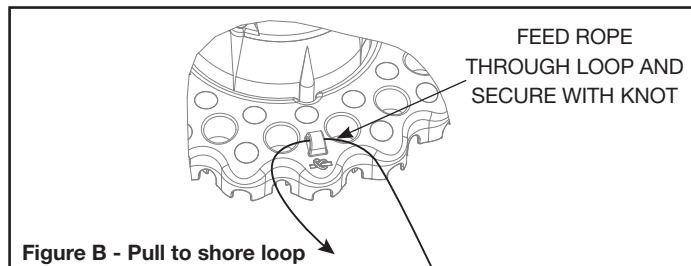

Figure B - Pull to shore loop

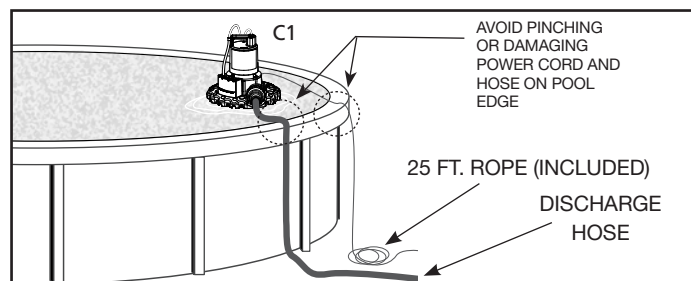

Figure C - Pull Across installation (side view)

C1. Connect provided 25 ft. rope to pull to shore loop (see Figure B) and discharge hose to the pump.

C2. Place pump on pool cover near edge of pool (see Figure C). If flotation device is used, place pump at the lowest point on the pool cover where water will collect.

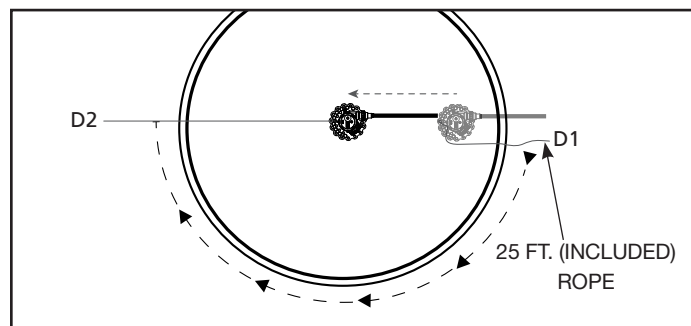

Figure D - Pull Across Installation (top view)

D1. Holding the provided 25 ft. rope, walk around pool until you are even with the pump on the opposite side.

D2. Pull the 25 ft. rope towards you until the pump is in the center of the pool cover where water will collect. Secure rope for easy removal (see Figure E) when weather permits. Plug in pump to allow for automatic operation.

NOTICE

Always use debris strainer when placing pump on a pool cover. The strainer helps protect the pool cover from damage, filters debris, and increases pump stability.

Operating Instructions and Parts Manual

PULL ACROSS - PUMP REMOVAL

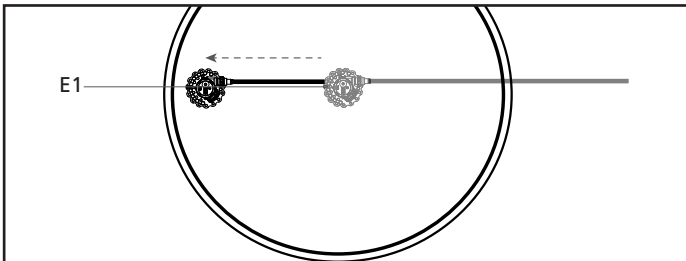

Figure E - Pull Across pump removal (top view)

E1. Disconnect power to pump. Using the included 25 ft. rope, safely pull pump to edge of pool, disconnect discharge hose and remove.

WARNING Never use power cord to position, carry or retrieve the pump.

DANGER Do NOT handle pump with wet hands or when standing in water or on a damp surface when the unit is operating or fails to operate. ALWAYS disconnect pump power cord from power source before handling. Do NOT bury cord. Visually locate cord to prevent damage caused by lawn mowers, hedge trimmers and other equipment. Failure to do so WILL result in fatal electrical shock.



5. The water level must be at least 2-1/8 inches for the pump to cycle, prime, and operate. Water levels less than 2-1/8 inches will not allow the impeller to contact water therefore no water will be pumped.
6. Plug the pump into a properly grounded 120 volt GFCI protected outlet. The pump will start automatically when the water reaches a depth of 2-1/8 inches. A priming delay of 2 seconds is programmed into the control to allow time for air to escape from the pumping chamber.

CAUTION Use caution when positioning the pump not to damage the power cord by dragging across the edge of the pool. Also take into consideration the placement of the discharge hose and power cord after installation. Make sure no sharp edge can damage the power cord or discharge hose causing unsafe conditions.

7. The pump will stop automatically once water has been removed to a depth of approximately 3/4 of an inch. The pump will NOT restart until the water depth rises to 2-1/8 inches or greater.
8. The pump will NOT allow itself to run dry. Once the pump detects that water is no longer being removed, it will shut down automatically. The pump must remain upright at all times in order for the water detection to function. Do NOT allow the pump to operate on its side or inverted. The shaft seal depends on water for lubrication, allowing the pump to remain in any other orientation than upright could cause shaft seal failure or pump failure.

NOTICE Do NOT alter the pump to override the automatic water detector. The shaft seal depends on water for lubrication. Overriding this pump feature CAN cause the pump to run dry and MAY damage the shaft seal and cause pump failure.

WARNING Pump starts automatically. Always disconnect electric supply before attempting to install, service, relocate, or perform any maintenance.

Minimal service is required for this pump. The motor housing of the pump is completely sealed and requires no service. If pump should fail to operate, perform the following troubleshooting guidelines:

MAINTENANCE

1. Verify pumping height does NOT exceed 15 feet (See Figure A). If pumping height is greater than 15 feet, this pumps automatic feature will not operate correctly.
2. Verify water depth is 2-1/8 inches or greater.
3. To verify pump is operating correctly.
 - a. Disconnect pump from power source.
 - b. Connect hose adapter/check valve and discharge hose to pump.
 - c. Immerse pump in a bucket or tub of water at least 2-1/8 inches in depth.
 - d. Place the other end of the discharge hose outside the bucket, so the water will pump out.
4. To verify discharge hose is free from a blockage.
 - a. Connect hose to another water source such as a faucet. If water flows through hose, return to step 3a. If water is restricted, verify discharge hose is unwound and remove all kinks, bends, or obstructions in hose.
 - b. If pump is still NOT operating, proceed to step 6.



WARNING
Electrocution Hazard!

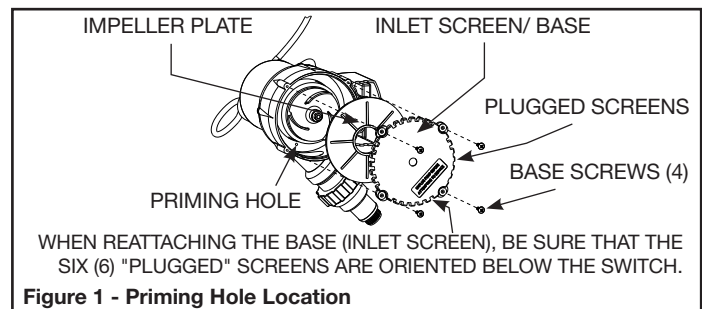

5. Periodic cleaning is required to maintain performance of the pump. Follow the cleaning steps listed below:
 - a. Disconnect pump from power source.
 - b. Remove the strainer.
 - c. Remove the four (4) base screws (Figure 1).
 - d. Remove the base and impeller plate.
 - e. Remove the debris and make sure the impeller turns freely.
 - f. Reinstall impeller plate, base, screws, and strainer.

MAINTENANCE (CON'T)

6. Check the priming hole for obstruction. (Figure 1). Follow the cleaning steps listed below:
 - a. Disconnect pump from power source.
 - b. Remove the strainer.
 - c. Remove the four (4) base screws (Figure 1).
 - d. Remove the base and impeller plate.
 - e. Use a pin or paperclip to clean the priming hole and air escape channel.
 - f. Reinstall impeller plate, base, screws and strainer.
7. If pump runs continuously, unplug the unit. Once unplugged, remove the strainer and check for debris stuck inside the sensor body (Figure 2). Remove any trapped leaves, debris or dirt.

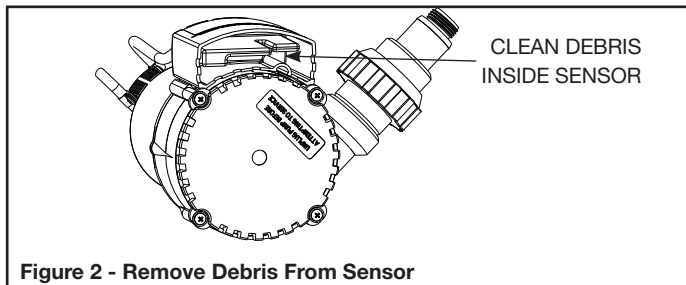

Figure 2 - Remove Debris From Sensor

8. If the pump cycles on and off too often the electronic switch may need cleaning. Disconnect pump from power source, remove the strainer and turn the pump upside down. The sensor probe will be visible inside

the switch housing. Clean inside the housing gently scrubbing with a small brush using soapy water. Then rinse thoroughly with clean water.

9. When temperatures drop below freezing remove pump from service and store indoors to protect pump from damage due to ice. The pump has a unique protection circuit to protect the motor from a locked impeller condition possibly caused by debris buildup or from a “frozen” impeller situation caused by ice formation. When the pump is activated and a locked impeller condition is detected the unit will automatically shutdown to protect the motor from overheating. The pump will continue this on/off cycle for a period of time to attempt to “free” the impeller until eventually the unit will remain off for a period of 12 hours checking twice a day for a “freed” impeller. Once the pump is able to operate correctly the pump will resume normal operation. To reset this delay without waiting 12 hours momentarily unplug the pump.

⚠ DANGER Do NOT use pump if any part of the switch housing or probe is cracked, broken or missing.

PUMPING HEIGHT

When water is pumped to an elevated position, any volume that has not reached the discharge outlet can flow back through the pump when the pump shuts off. This back-flow can cause the water level in small areas to rise enough to re-start the pump. The check valve/hose adapter included is required in this situation. For proper operation, make certain the check valve is oriented as instructed on check valve body.

NOTICE In small areas a check valve is required to prevent backflow. Without a check valve the pump may cycle continuously and potentially wear out the pump components.

Troubleshooting Chart

⚠ DANGER Electrocutation Hazard! Pump starts automatically. Disconnect the power before attempting any repairs. Failure to follow WILL result in serious injury or death.

Symptom	Possible Cause(s)	Corrective Action
Pump will not start or run	<ol style="list-style-type: none"> 1. Tripped home electrical breaker 2. GFCI tripped 3. Low line voltage 4. Defective motor 5. Dirty switch 6. Impeller obstructed 7. Inlet screen or strainer clogged 8. Priming hole plugged 	<ol style="list-style-type: none"> 1. Reset breaker 2. Check for damaged wiring or moisture 3. Contact electrician 4. Replace pump 5. Rinse out switch with clean water (Figure 2) 6. Remove strainer, base, and impeller plate (Figure1) check for debris; clean 7. Clean inlet screen and debris strainer (Figure 1) 8. Clean hole, inside volute housing, with a pin or paper clip (Figure 1)
Pump starts and stops too often	<ol style="list-style-type: none"> 1. Backflow of water from piping 2. Dirty switch 3. Priming hole plugged 4. Pump is sitting uneven on pool or spa cover 	<ol style="list-style-type: none"> 1. Install or replace check valve 2. Rinse out switch with clean water (Figure 2) 3. Clean hole, inside volute housing, with a pin or paper clip (Figure 1) 4. Reposition pump so pump sits level on cover
Pump will not shut off or runs continuously	<ol style="list-style-type: none"> 1. Debris in switch 2. Discharge height exceeds capability 	<ol style="list-style-type: none"> 1. Rinse out switch with clean water (Figure 2) 2. Reduce discharge height
Pump operates but delivers little or no water	<ol style="list-style-type: none"> 1. Impeller obstructed 2. Priming hole plugged 3. Obstructed hose 4. Discharge height exceeds capability 5. Strainer clogged 	<ol style="list-style-type: none"> 1. Remove strainer, base, and impeller plate (Figure 1), check for debris; clean 2. Clean hole, inside volute housing, with a pin or paper clip (Figure 1) 3. Check for kinks, reposition hose or check for debris 4. Reduce discharge height 5. Unplug pump. Remove strainer and rinse with clean water to remove debris

CALIFORNIA PROPOSITION 65

⚠ WARNING This product or its power cord may contain chemicals, including lead, known to the State of California to cause cancer and birth defects or other reproductive harm. Wash hands after handling.

**For Replacement Parts or
Technical Assistance, call
1-800-237-0987**

Please provide following information:

- Model number
- Serial number (if any)
- Part description and number as shown in parts list

Address parts correspondence to:

WAYNE Water Systems
101 Production Drive
Harrison, OH 45030 U.S.A.

Ref. No.	Description	Order No.	Quantity
1	Check valve /garden hose adapter	62061-001	1
2	Strainer	28232-001	1
3	25' Rope	67152-001	1

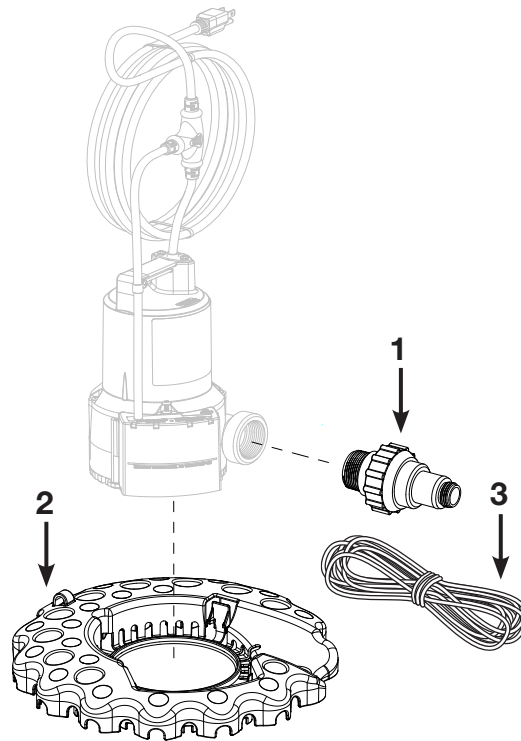

Limited Warranty

For three years from the date of purchase, WAYNE Water Systems Division ("WAYNE Pumps") will repair or replace, at its option, for the original purchaser any part or parts of its Water Pumps ("Product") found upon examination by WAYNE to be defective in materials or workmanship. Please call WAYNE Pumps (1-800-237-0987) for instructions. Be prepared to provide the model number and the serial number when exercising this warranty. All transportation charges on Products or parts submitted for repair or replacement must be paid by purchaser.

This Limited Warranty does not cover Products which have been damaged as a result of accident, abuse, misuse, neglect, improper application, improper maintenance, or failure to operate in accordance with WAYNE Pumps' written instructions.

THERE IS NO OTHER EXPRESS WARRANTY. IMPLIED WARRANTIES, INCLUDING THOSE OF MERCHANTABILITY AND FITNESS FOR A PARTICULAR PURPOSE, ARE LIMITED TO ONE YEAR FROM THE DATE OF PURCHASE. THIS IS THE EXCLUSIVE REMEDY AND ANY LIABILITY FOR ANY AND ALL INDIRECT OR CONSEQUENTIAL DAMAGES OR EXPENSES WHATSOEVER IS EXCLUDED.

Some states do not allow limitations on how long an implied warranty lasts, or do not allow the exclusions or limitations of incidental or consequential damages, so the above limitations might not apply to you. This limited warranty gives you specific legal rights, and you may also have other legal rights which vary from state to state.

In no event, whether as a result of breach of contract warranty, tort (including negligence) or otherwise, shall WAYNE Pumps or its suppliers be liable for any special, consequential, incidental or penal damages including, but not limited to loss of profit or revenues, loss of use of the products or any associated equipment, damage to associated equipment, cost of capital, cost of substitute products, facilities, services or replacement power, downtime costs, or claims of buyer's customers for such damages.

You **MUST** retain your purchase receipt along with this form. In the event you need to exercise a warranty claim, you **MUST** send a **copy** of the purchase receipt along with the material or correspondence. Please call WAYNE Pumps (800-237-0987) for return authorization and instructions.

DO NOT MAIL THIS FORM TO WAYNE PUMPS. Use this form only to maintain your records.

MODEL NO. _____ SERIAL NO. _____ DATE _____

ATTACH YOUR RECEIPT HERE

LIRE, COMPRENDRE ET SUIVRE TOUTES LES INSTRUCTIONS DANS CE MANUEL - NE PAS JETER .
Le non-respect de ces instructions pourrait mener à des dommages, des blessures graves ou la mort.

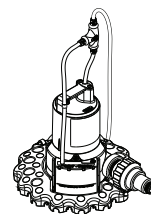

INSTRUCTIONS DE DÉMARRAGE RAPIDE

WAPC250

ÉTAPE 1 - VÉRIFICATION DU CONTENU DU PAQUET

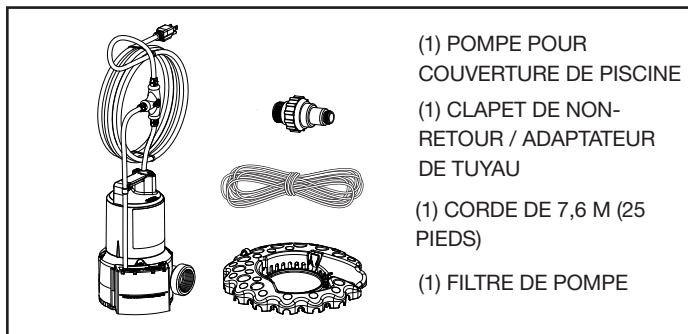

ÉTAPE 5 - FIXATION DE LA CORDE AU FILTRE

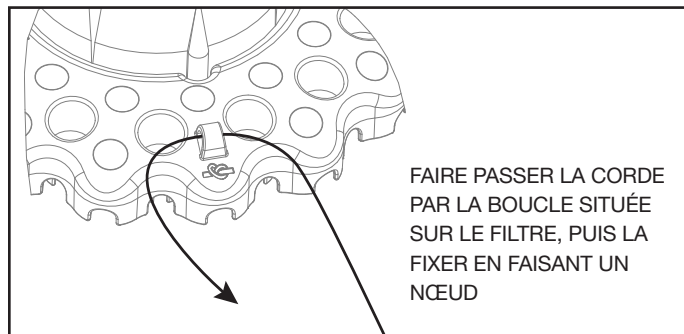

ÉTAPE 2 - INSTALLATION DU CLAPET DE NON-RETOUR

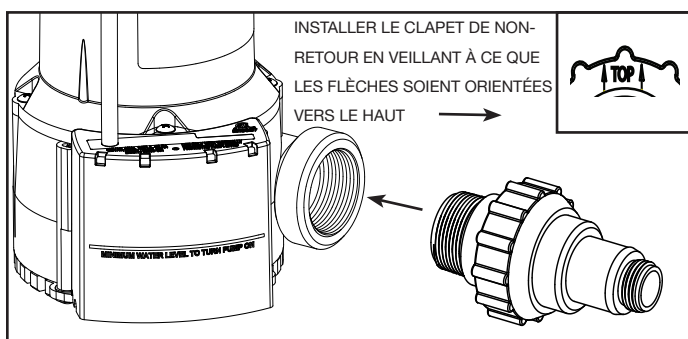

ÉTAPE 6 - POSITIONNEMENT SUR LA COUVERTURE DE LA PISCINE

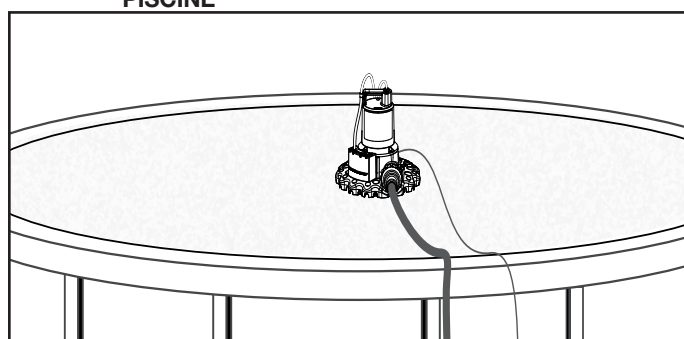

ÉTAPE 3 - FIXATION DU FILTRE

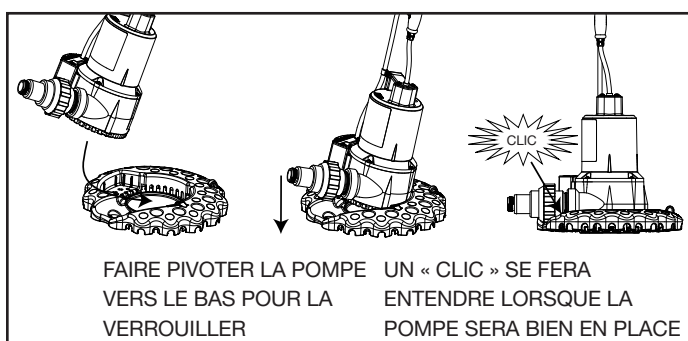

ÉTAPE 7 - BRANCHEMENT DANS UNE PRISE À DISJONCTEUR DE FUITE À LA TERRE

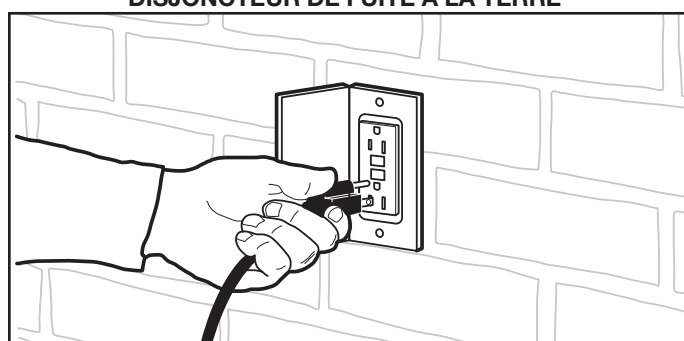

ÉTAPE 4 - RACCORDEMENT DU TUYAU D'ARROSAGE

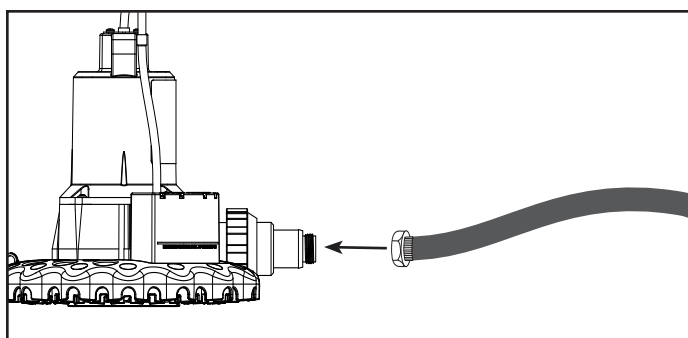

POUR LES AUTRES TECHNIQUES DE POSITIONNEMENT ET LA PROCÉDURE D'INSTALLATION DÉTAILLÉE POUR LES PISCINES ENTERRÉES ET HORS-SOL, SE REPORTER - FIGURES (A-E).

Pour de l'information sur les pièces, les produits et l'entretien, visiter www.waynepumps.com